

UPDATE: 12/98

CD Changer Installation Instructions for:

1999 BMW 5 Series Sedan (E39)

Mounting of CD Changer
In Factory Left-Rear Trunk Area

Part Description	Current E39 Kit P/N 82 11 1 469 911	QTY	New E39 Kit P/N 82 11 1 469 911	QTY
Main CD-C bracket	65 12 8 371 137	1	85 12 8 361 453	1
Main base bracket	65 12 8 361 452	1	65 12 8 361 452	1
M5x14 bolt	07 11 9 915 113	6	07 11 9 915 113	3
Clip nuts	61 13 1 372 033	6	61 13 1 372 033	3
Screw	07 11 9 916 946	1	07 11 9 916 946	1
Cap nut	51 71 1 934 930	2	51 71 1 934 930	2
Nylon insert nut	63 17 1 367 868	1	63 17 1 367 868	1
CD sub bracket	65 12 8 371 136	1	N/A	0

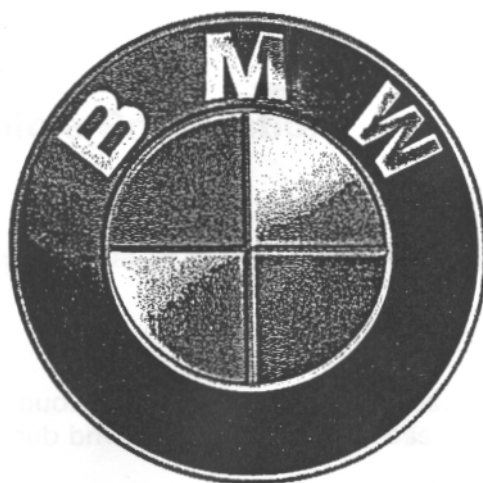

Installation Instruction P/N 99 00 0 001 756

BMW of North America, Inc.
Product & Service Engineering Dept.
December 1998

GENERAL INFORMATION

INTRODUCTION

These installation instructions were produced to give the installation technician all necessary information to properly install the BMW CD Changer in the left side rear trunk area in all E39 sedan vehicles.

These instructions were developed by the Product and Service Engineering Department of BMW of North America, Inc. specifically for BMW vehicles and are not to be compared to any existing products for vehicles other than BMW.

These instructions were complete and up to date at time of issue. Any changes in the vehicle or problems noted by the installer should be reported directly to BMW Product and Service Engineering Department. Questions regarding this installation should be directed to the BMW Technical Hotline.

Read all instructions carefully before proceeding with this installation. LH (left hand) and RH (right hand) are referenced as determined from sitting in the driver's seat facing forward. Instructions dealing with a common disassembly procedure are referenced to the TIS file found on the DIS Tester.

REQUIRED TOOLS

Common hand tools

NECESSARY VEHICLE PREPARATION

Step 1

First, access the CD changer location in the left rear cargo area by opening the cosmetic cover

Step 2

Locate the CD changer audio and power/I-Bus cables. Position the cables to avoid pinching them during the sub bracket installation process

PREINSTALLATION

All vehicles with factory pre-wiring should have the CD audio cable inserted into the (17 pin) Radio Connector. Before starting installation of the CD changer, check that the CD audio cable is secured in place with the Lock Pin (see Figure 1)

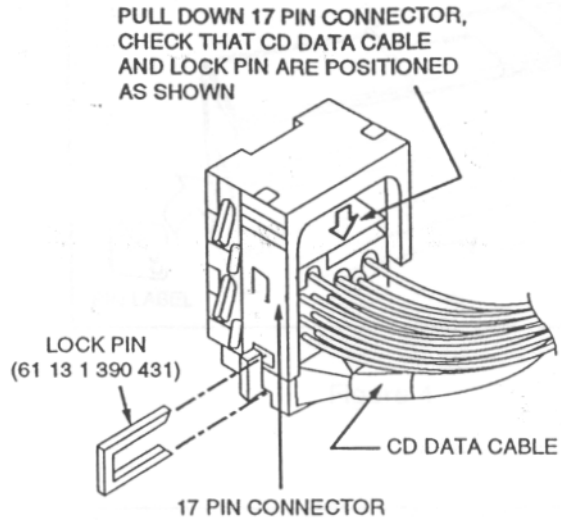

Figure 1

CD CHANGER PREPARATION

Shipping screws are installed on the bottom of the CD changer to protect the unit during shipment. Prior to installation, make sure you remove the shipping screws and cover the holes with the supplied adhesive seals as described below.

1. Remove the 3 shipping screws from the bottom of the CD changer (see Figure 2). Store the 3 screws for future use; replace 3 screws only if a unit needs to be returned for an exchange.
2. Cover the holes where the shipping screws were installed with the 3 adhesive seals supplied with the unit. (see Figure 2)
3. Change the position of the horizontal / vertical Spring Pin on both sides of the CD changer to the Vertical (h position (see Figure 3). (The unit is shipped with the Spring Pin in the Horizontal position.)

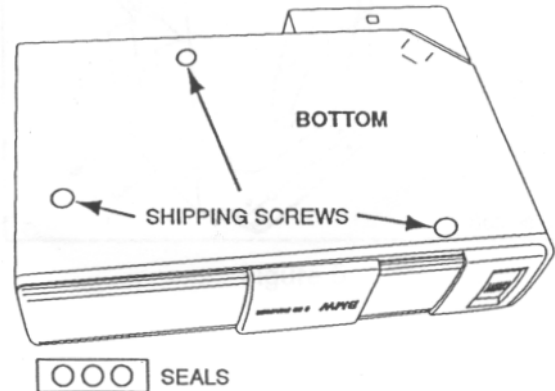

Figure 2

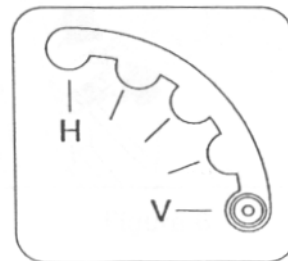

Figure 3

4. To protect the Spring Pin, cover the Pin area with the supplied Pin Label by aligning the two diagonally opposite holes with H and V positions (see Figure 4).

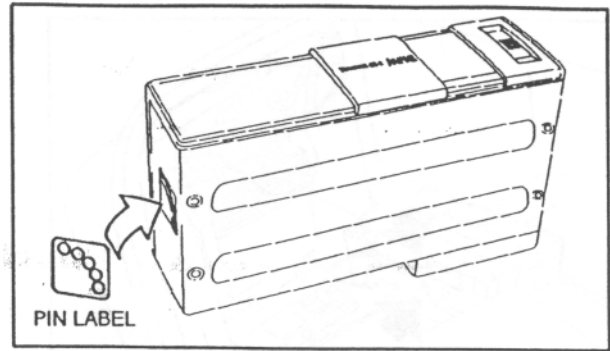

Figure 4

INSTALLATION

5. Attach the mounting bracket to the CD Changer using the mounting hardware (M4) shipped with the CD Changer. Use lower mounting holes for Left side and higher ones for right side (see Figure 5).

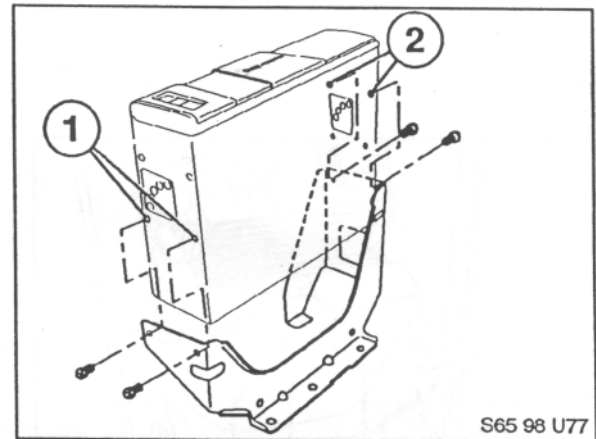

Figure 5

7. Locate the CD Audio Cable (6-pin) and Power/I-Bus Cable (3-pin), which are terminated behind CD changer Trunk Trim Cover in the left side (driver's side) of the trunk (see Figure 6).

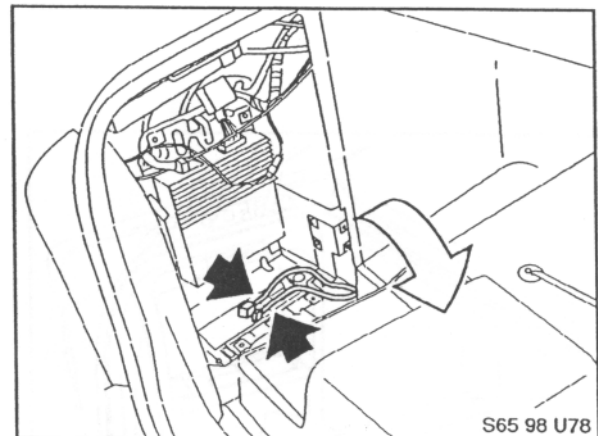

Figure 6

8. Connect CD audio and Power/I-Bus cables to CD changer (see Figure 7).

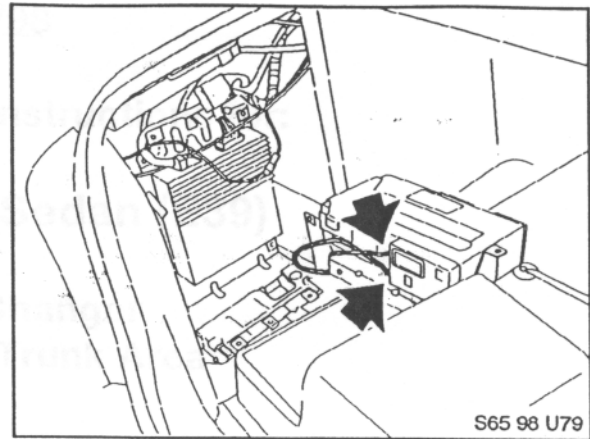

Figure 7

9. First, install a M5 bolt to front threaded body nut loosely. Then, install 4 other bolts to remaining 4 body nuts (see Figure 8).

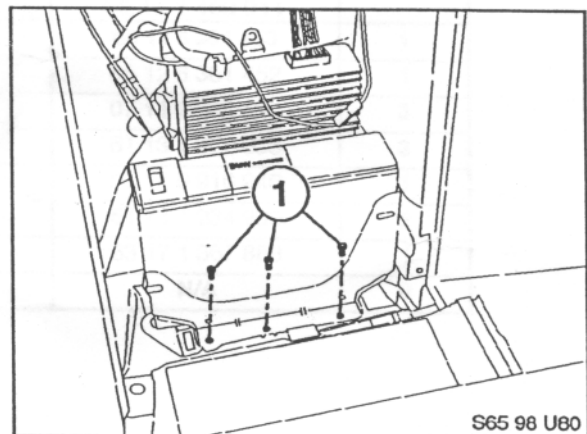

Figure 8

10. Remove tray pocket from CD changer Trunk Trim Cover and place CD changer trunk trim bezel over CD changer (See Figure 9).

FINAL INSTALLATION

11. Inspect all cable/wire routings and secure with tie-wraps where necessary.
12. Test/operate per Owner's Manual.
13. Replace all interior components.

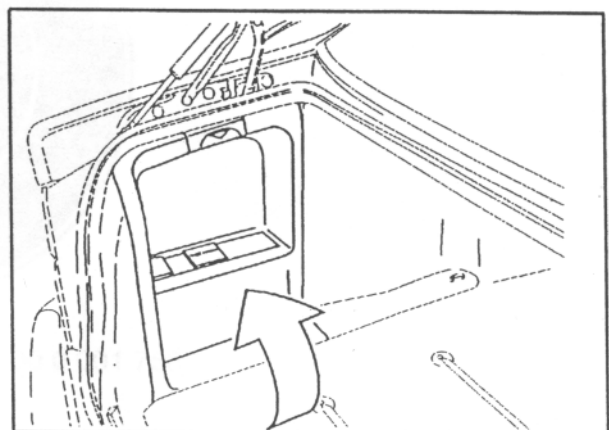

Figure 9